

Rectangular 10 Turn Dial (3 Digit), (4 Digit) 100 Turn



FEATURES

- Rectangular digital scale
- 1" wide
- 1/4" or 1/8" or metric (6 mm) shaft adapter
- Open or clear plastic window bezel
- Black anodize finish with standard or white bezel trim
- Satin clear anodize finish



RoHS
COMPLIANT

MECHANICAL SPECIFICATIONS	
PARAMETER	
Numerals	The numerals shall be white on a black background and 0.130" H (3.30 cm)
Mounting	The spring detented knob shall be removed using a straight pull, exposing two No. 4-40 hex socket set screws for mounting the dial directly to the component shaft
Weight	1.6 oz. (45.36 g)

OPERATIONAL SPECIFICATIONS	
Operation 3 Digit (10 turn) Left Digit Right Two Digits	Complete revolutions of turning knob Percent of revolution The unit registers a total count of 999
Operation 4 Digit (100 Turn) Left Two Digits Right Two Digits	Complete revolutions of turning knob Percent of revolution The unit registers a total count of 9999
Rotation	The indication shall increase with clockwise rotation of the turning knob
Accuracy	Graduation lines adjacent to the numerals on the right digit wheel indicate settings 0.2 % of a revolution of the turning knob
Phasing	Dial phased by rotating the exposed component shaft to correspond with the desired reading on the dial prior to tightening the set screws

DIMENSIONS in inches (millimeters)

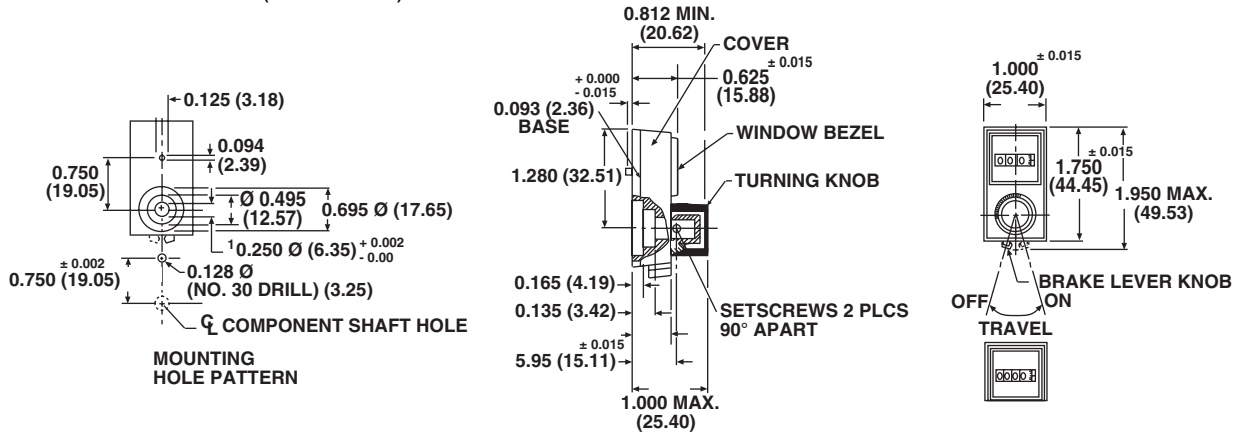

ORDERING INFORMATION/DESCRIPTION					
15	A	1	1	B010	e
MODEL	SHAFT DIAMETER AND NUMERICAL DISPLAY	BEZEL	FINISH	PACKAGING	LEAD FINISH
Example: 15 - A - 1 - 1	A 1/4" dia. 3 digit B 1/4" dia. 4 digit C 1/8" dia. 3 digit D 1/8" dia. 4 digit E 6 mm dia. 3 digit F 6 mm dia. 4 digit	1. Open 3. Clear plastic window	1. Satin clear anodize 3. Black anodize, white bezel trim 5. Black anodize		

SAP PART NUMBERING GUIDELINES				
15	A	1	1	B10
MODEL	SHAFT DIAMETER	BEZEL	FINISH	PACKAGING



Disclaimer

All product specifications and data are subject to change without notice.

Vishay Intertechnology, Inc., its affiliates, agents, and employees, and all persons acting on its or their behalf (collectively, "Vishay"), disclaim any and all liability for any errors, inaccuracies or incompleteness contained herein or in any other disclosure relating to any product.

Vishay disclaims any and all liability arising out of the use or application of any product described herein or of any information provided herein to the maximum extent permitted by law. The product specifications do not expand or otherwise modify Vishay's terms and conditions of purchase, including but not limited to the warranty expressed therein, which apply to these products.

No license, express or implied, by estoppel or otherwise, to any intellectual property rights is granted by this document or by any conduct of Vishay.

The products shown herein are not designed for use in medical, life-saving, or life-sustaining applications unless otherwise expressly indicated. Customers using or selling Vishay products not expressly indicated for use in such applications do so entirely at their own risk and agree to fully indemnify Vishay for any damages arising or resulting from such use or sale. Please contact authorized Vishay personnel to obtain written terms and conditions regarding products designed for such applications.

Product names and markings noted herein may be trademarks of their respective owners.